

SC/9.1

Starlink Project
Starlink Cookbook 9.1

M D Lawden
Anne Charles

14 May 1997

Copyright © 1997 Council for the Central Laboratory of the Research Councils

L^AT_EX Cookbook

Abstract

This cookbook shows some examples of L^AT_EX in action and should help you to get to know how to use L^AT_EX effectively.

Contents

1	Introduction	1
2	Document structure	2
3	Font size and type	4
4	Lists	6
5	Displays	9
6	Routine specifications	14
7	Mathematics	16
8	Tabbing	20
9	Tables	24
10	Figures	28

List of Figures

1	Functional analysis of INTERIM routines	30
2	SCAR Help system	32
3	Data flow in the editing process	32
4	The relationship between VMS and HDS	34
5	Diagrams of Structure Objects	36
6	An Alternative Representation for SKY_POSITION	38
7	Structure of a Record Control Label	38
8	The pointing flow	41
9	Transformations for mean $[\alpha, \delta]$	44

1 Introduction

This paper shows some examples of \LaTeX in action and should help you to get to know how to use \LaTeX effectively. Sample inputs to \LaTeX are shown on the left hand pages and the output they generate when processed by \LaTeX is shown on the opposite page. When starting to prepare a \LaTeX document, copy a skeleton such as `/star/docs/sun.tex` and edit as required.

These examples are just to enable you to get going quickly with \LaTeX and are not meant to be exhaustive. Also, I do not claim that these techniques are the best possible; only that they work. For serious users, there is no substitute for Leslie Lamport's book " \LaTeX User's Guide & Reference Manual". Copies of this book may be available for loan; ask your Site Manager. You should also read SUN/9 before attempting to use \LaTeX .

The methods shown in this paper were stolen from many sources. If you see a format in a Starlink paper that you like, you can always look in the document source in `/star/docs` to see how it was done.

2 Document structure

```
\section {Introduction}
  <text>
\section{The Starlink Project}
  <text>
\subsection{Operation and Management}
  <text>
\section{Users}
  <text>
\section{Finding information}
  <text>
\subsection{VAX Documents}
  <text>
\subsection{Starlink Documents}
  <text>
\subsection{On-line Files}
  <text>
\subsubsection{Starlink documents}
  <text>
\subsubsection{Information summaries}
  <text>
\paragraph {Starlink-wide information}
  <text>
\paragraph {Local information}
  <text>
\subsubsection{Internal documents}
  <text>
\subsubsection{Hints}
  <text>
\section{Hardware}
  <text>
\section{Software}
  <text>
\appendix
\section{Personnel}
  <text>
\section{Inventory}
  <text>
```

L^AT_EX OUTPUT**1 Introduction****2 The Starlink Project****2.1 Operation and Management****3 Users****4 Finding information****4.1 VAX Documents****4.2 Starlink Documents****4.3 On-line Files****4.3.1 Starlink documents****4.3.2 Information summaries****Starlink-wide information****Local information****4.3.3 Internal documents****4.3.4 Hints****5 Hardware****6 Software****A Personnel****B Inventory**

3 Font size and type

You can use a large number of different sizes and types of font. This is the one you get by default.

```

\vspace{10mm}

\begin{quote}

\textrm{This is Rom style --- 1 2 3 4.}

\emph{This is Emph style --- 1 2 3 4.}

\textbf{This is Bold style --- 1 2 3 4.}

\textit{This is Ital style --- 1 2 3 4.}

\textsl{This is Slan style --- 1 2 3 4.}

\textsf{This is SSrf style --- 1 2 3 4.}

\textsc{This is caps style --- 1 2 3 4.}

\texttt{This is Type style --- 1 2 3 4.}

{\tiny This is tiny size.}

{\scriptsize This is scriptsize.}

{\footnotesize This is footnotesize.}

{\small This is small size.}

{\normalsize This is normalsize.}

{\large This is large size.}

{\Large This is Large size.}

{\LARGE This is LARGE size.}

{\huge This is huge size.}

{\Huge This is Huge size.}

\end{quote}

\vspace{10mm}

```

The full selection of fonts available is illustrated in [\xref{SUN/93}{sun93}{}](#).

L^AT_EX OUTPUT

You can use a large number of different sizes and types of font. This is the one you get by default.

This is Rom style — 1 2 3 4.

This is Emph style — 1 2 3 4.

This is Bold style — 1 2 3 4.

This is Ital style — 1 2 3 4.

This is Slan style — 1 2 3 4.

This is SSrf style — 1 2 3 4.

THIS IS CAPS STYLE — 1 2 3 4.

This is Type style -- 1 2 3 4.

This is tiny size.

This is scriptsize.

This is footnotesize.

This is small size.

This is normalsize.

This is large size.

This is Large size.

This is LARGE size.

This is huge size.

This is Huge size.

The full selection of fonts available is illustrated in SUN/93.

4 Lists

```

Starlink staff:
\begin{itemize}
  \item manage the project.
  \item support users and programmers.
  \begin{itemize}
    \item answer the phone.
    \item answer mail messages.
    \item soothe those having a nervous breakdown.
  \end{itemize}
  \item maintain contact with other astronomical groups.
\end{itemize}

*****

FIELDNAMES used in the CAR system are:
\begin{description}
  \item [TITLE] -
    This contains the name of the catalogue and is mandatory.
    FORMAT2 should be A.
    VALUE should be a mnemonic ($<$6 characters).
    COMMENT should be the ordinary title.
  \item [MEDIUM] -
    This is the storage medium of the data and is mandatory.
    FORMAT2 should be A.
    VALUE should be:
    \begin{description}
      \item [TAPE] -
        to select magnetic tape.
      \item [DISK] -
        to select disk.
    \end{description}
  \item [ACCESSMODE] -
    This is the mode of getting records from and putting them into the file.
    FORMAT2 should be A.
    VALUE should be SEQUENTIAL, DIRECT or KEYED; the latter is for access to
    Indexed Sequential Accessmode Files.
    ACCESSMODE is mandatory when MEDIUM is DISK.
\end{description}

*****

This is an invitation to input one of the following:
\begin{enumerate}
  \item The name of an application program,
  \item The name of a ICL procedure,
  \begin{enumerate}
    \item Actual name
    \item Logical name
  \end{enumerate}
  \item A ICL command
\end{enumerate}

```

with an optional argument list.

In cases 1 and 2 a search is carried out for the executable image file or procedure file.

L^AT_EX OUTPUT

Starlink staff:

- manage the project.
- support users and programmers.
 - answer the phone.
 - answer mail messages.
 - soothe those having a nervous breakdown.
- maintain contact with other astronomical groups.

FIELDNAMEs used in the CAR system are:

TITLE - This contains the name of the catalogue and is mandatory. FORMAT2 should be A. VALUE should be a mnemonic (<6 characters). COMMENT should be the ordinary title.

MEDIUM - This is the storage medium of the data and is mandatory. FORMAT2 should be A. VALUE should be:

TAPE - to select magnetic tape.

DISK - to select disk.

ACCESSMODE - This is the mode of getting records from and putting them into the file. FORMAT2 should be A. VALUE should be SEQUENTIAL, DIRECT or KEYED; the latter is for access to Indexed Sequential Accessmode Files. ACCESSMODE is mandatory when MEDIUM is DISK.

This is an invitation to input one of the following:

- (1) The name of an application program,
- (2) The name of a DSCL procedure,
 - (a) Actual name
 - (b) Logical name
- (3) A DSCL or DCL command

with an optional argument list. In cases 1 and 2 a search is carried out for the executable image file or procedure file.

5 Displays

There are three main areas of help information: CAR_HELP for information about the CAR routines; CAT_HELP for information about the catalogues and SCAR_HELP for general information.

```
\begin{terminalv}

ICL> CAR_HELP
SCAR COMMANDS Subtopic? CAR_SEARCH

\end{terminalv}
```

You would find information about the CAR_SEARCH procedure.

```
\begin{terminalv}

ICL> CAT_HELP
Topic? $Summary

\end{terminalv}
```

The catalogues are summarised in this help library.
The acronym for the IRAS point source catalogue is IRPS.

The parameters\footnote{By the way, this is how to insert a footnote} before the ‘;’ are input parameters; those after are output parameters.
Routines belonging to the HDS kernel are identified by the symbol ‘[K]’.

```
\noindent
\textbf{CMP\_GET0x}\emph{(loc,name,value,status)} --- Read scalar component\\
\textbf{CMP\_GET1x}\emph{(loc,name,elx,value,el,status)} --- Read vector component\\
\textbf{CMP\_GETNx}\emph{(loc,name,ndim,dimx,value,dim,status)} --- Read array
component\\
\textbf{CMP\_GETVx}\emph{(loc,name,elx,value,el,status)} --- Read vectorised
component\\
\textbf{CMP\_LEN}\emph{(loc,name;len,status)} --- Enquire component precision\\
```

These are the catalogues online at RAL, (R = Access restricted):

```
\begin{quote}
  \begin{description}
    \item [AIPS] -- Associations of IRAS point sources.
    \item [AS85] -- CHART Astrometry catalogue.
    \item [ASIR] -- Global Index for AIPS and IRPS.
    \item [ASSC] -- Associations of IRAS Small Scale Structure Catalogue.
    \item [CATX] -- Catalogue X: Merger of UGC, ESOB, CGCG.
    \item [CSIS] -- CHART CSI 1979 Version.
  \end{description}
\end{quote}
```

L^AT_EX OUTPUT

There are three main areas of help information: CAR_HELP for information about the CAR routines; CAT_HELP for information about the catalogues and SCAR_HELP for general information.

```
ICL> CAR_HELP
SCAR COMMANDS Subtopic? CAR_SEARCH
```

You would find information about the CAR_SEARCH procedure.

```
ICL> CAT_HELP
Topic? $Summary
```

The catalogues are summarised in this help library. The acronym for the IRAS point source catalogue is IRPS.

The parameters¹ before the ‘;’ are input parameters; those after are output parameters. Routines belonging to the HDS kernel are identified by the symbol ‘[K]’.

CMP_GET0x(*loc,name;value,status*) — Read scalar component
CMP_GET1x(*loc,name,elx;value,el,status*) — Read vector component
CMP_GETNx(*loc,name,ndim,dimx;value,dim,status*) — Read array component
CMP_GETVx(*loc,name,elx;value,el,status*) — Read vectorised component
CMP_LEN(*loc,name;len,status*) — Enquire component precision

These are the catalogues online at RAL, (R = Access restricted):

- AIPS** – Associations of IRAS point sources.
- AS85** – CHART Astrometry catalogue.
- ASIR** – Global Index for AIPS and IRPS.
- ASSC** – Associations of IRAS Small Scale Structure Catalogue.
- CATX** – Catalogue X: Merger of UGC, ESOB, CGCG.
- CSIS** – CHART CSI 1979 Version.

¹By the way, this is how to insert a footnote

The error status code symbol is constructed by concatenating the string 'ERR__' with an error code.

The error codes and their meanings are listed below:

```
\begin{description}
  \item [DIMINV]:
    \emph{Dimensions invalid (out-of-range)}.
    It is likely that certain groups of users will be restricted in the size of the
    frames they can access.
    RDIMAG and WRIMAG return this status if the user has insufficient quota to map
    the frame.
    This status will also be set when attempting to create an output frame of a
    negative or zero size.
  \item [DSCNPR]:
    \emph{Descriptor item not present}.
    For DLDSR and RDDSCR, the specified descriptor item name cannot be found within
    the frame's descriptor.
    For RDDSCN, no item can be found with the specified name as the end of the
    descriptor list was encountered.
\end{description}
```

This program allows you to specify fields within any catalogue and then perform statistical analysis on the selected fields(s).

```
\begin{description}
  \item [ANALYSE/HISTOGRAM] --
    This is option 1 on the first menu.
    You will be prompted for the name of the input catalogue and the name of the
    field to be analysed.
    The field values are read in from the catalogue and the mean, mode standard
    deviation, maximum and minimum values are presented to you.
    You can identify any statistic by looking up HIST in the help libraries.
    You should note X\_MAX, X\_MIN and MODE\_SZ for designing the axis scales of
    your plot.
  \begin{description}
    \item [Prompts] --
      \begin{description}
        \item [STYLE] -- The user selection from a menu.
          The expected input is an integer and ranges from the values shown on the menu.
        \item [INPUT] -- The name of the catalogue from which the field is to be taken.
        \item [PTYPE] - The type of plot you want; this is either a connected point graph or
          a standard histogram.
      \end{description}
    \end{description}
  \item [ANALYSE/SCATTERPLOT] --
    This is option 2 on the first menu.
    Linear regression is performed on the two specified fields and then a scatter
    diagram with the line of best fit is plotted.
  \begin{description}
    \item [Prompts] --
      \begin{description}
        \item [STYLE]-- Select from a menu; the expected input is an integer
          and ranges from the values shown on the menu.
        \item [INPUT] -- The name of the catalogue from which the field is to be taken.
      \end{description}
  \end{description}
```

```
\end{description}  
\end{description}  
\end{description}
```

L^AT_EX OUTPUT

The error status code symbol is constructed by concatenating the string 'ERR_' with an error code. The error codes and their meanings are listed below:

DIMINV : *Dimensions invalid (out-of-range)*. It is likely that certain groups of users will be restricted in the size of the frames they can access. RDIMAG and WRIMAG return this status if the user has insufficient quota to map the frame. This status will also be set when attempting to create an output frame of a negative or zero size.

DSCNPR : *Descriptor item not present*. For DLDSCR and RDDSCR, the specified descriptor item name cannot be found within the frame's descriptor. For RDDSCN, no item can be found with the specified name as the end of the descriptor list was encountered.

This program allows you to specify fields within any catalogue and then perform statistical analysis on the selected fields(s).

ANALYSE/HISTOGRAM – This is option 1 on the first menu. You will be prompted for the name of the input catalogue and the name of the field to be analysed. The field values are read in from the catalogue and the mean, mode standard deviation, maximum and minimum values are presented to you. You can identify any statistic by looking up HIST in the help libraries. You should note X_MAX, X_MIN and MODE_SZ for designing the axis scales of your plot.

Prompts –

STYLE – The user selection from a menu. The expected input is an integer and ranges from the values shown on the menu.

INPUT – The name of the catalogue from which the field is to be taken.

PTYPE - The type of plot you want; this is either a connected point graph or a standard histogram.

ANALYSE/SCATTERPLOT – This is option 2 on the first menu. Linear regression is performed on the two specified fields and then a scatter diagram with the line of best fit is plotted.

Prompts –

STYLE – Select from a menu; the expected input is an integer and ranges from the values shown on the menu.

INPUT – The name of the catalogue from which the field is to be taken.

6 Routine specifications

```

This appendix documents the INTERIM routines in alphabetical order.\\
\rule{\textwidth}{0.3mm}
{\Large \textbf{ADDDSCR} \hfill Add Descriptor Item \hfill \textbf{ADDDSCR}}
\begin{description}
  \item [FUNCTION]:
    Writes a new item in a frame descriptor.
    In general, the item value is a vector of elements.
    If an item with the same name already exists in the descriptor, the supplied
    elements are appended to the existing ones.
  \item [CALL]:
  \begin{quote}
    \texttt{ CALL ADDSCR(name,descr,value,nels,status)}
  \end{quote}
  \item [INPUT ARGUMENTS]:
  \begin{tabbing}
    descrxxx=\CHARACTERx\=expressionxxx\=\kill
    \emph{name}\>CHARACTER\>expression\>Parameter name (FRAME class).\\
    \emph{descr}\>CHARACTER\>expression\>Descriptor item name.\\
    \emph{value}\>CHARACTER\>array\>Element values.\\
    \emph{nels}\>INTEGER\>expression\>Number of elements in \emph{value}.
  \end{tabbing}
  \item [OUTPUT ARGUMENT]:
  \begin{tabbing}
    descrxxx=\CHARACTERx\=expressionxxx\=\kill
    \emph{status}\>INTEGER\>variable\>Status return.
  \end{tabbing}
\end{description}
\goodbreak
\rule{\textwidth}{0.3mm}
{\Large \textbf{DLDSCR} \hfill Delete Descriptor Item \hfill \textbf{DLDSCR}}
\begin{description}
  \item [FUNCTION]:
    Deletes an existing descriptor item from a frame.
  \item [CALL]:
  \begin{quote}
    \texttt{ CALL DLDSCR(name,descr,status)}
  \end{quote}
  \item [INPUT ARGUMENTS]:
  \begin{tabbing}
    descrxxx=\CHARACTERx\=expressionxxx\=\kill
    \emph{name}\>CHARACTER\>expression\>Parameter name (FRAME class).\\
    \emph{descr}\>CHARACTER\>expression\>Descriptor item name.
  \end{tabbing}
  \item [OUTPUT ARGUMENT]:
  \begin{tabbing}
    descrxxx=\CHARACTERx\=expressionxxx\=\kill
    \emph{status}\>INTEGER\>variable\>Status return.
  \end{tabbing}
\end{description}
\goodbreak

```

L^AT_EX OUTPUT

This appendix documents the INTERIM routines in alphabetical order.

ADDSCR	Add Descriptor Item	ADDSCR
---------------	----------------------------	---------------

FUNCTION : Writes a new item in a frame descriptor. In general, the item value is a vector of elements. If an item with the same name already exists in the descriptor, the supplied elements are appended to the existing ones.

CALL :

CALL ADDSCR(name,descr,value,nels,status)

INPUT ARGUMENTS :

<i>name</i>	CHARACTER expression	Parameter name (FRAME class).
<i>descr</i>	CHARACTER expression	Descriptor item name.
<i>value</i>	CHARACTER array	Element values.
<i>nels</i>	INTEGER expression	Number of elements in <i>value</i> .

OUTPUT ARGUMENT :

<i>status</i>	INTEGER	variable	Status return.
---------------	---------	----------	----------------

DLDSCR	Delete Descriptor Item	DLDSCR
---------------	-------------------------------	---------------

FUNCTION : Deletes an existing descriptor item from a frame.

CALL :

CALL DLDSCR(name,descr,status)

INPUT ARGUMENTS :

<i>name</i>	CHARACTER expression	Parameter name (FRAME class).
<i>descr</i>	CHARACTER expression	Descriptor item name.

OUTPUT ARGUMENT :

<i>status</i>	INTEGER	variable	Status return.
---------------	---------	----------	----------------

7 Mathematics

The optional globular cluster is generated using a King (1962) star density law

$$D(r) = k \left(\left(1 + \left(\frac{r}{r_c} \right)^2 \right)^{-1/2} - \left(1 + \left(\frac{r_t}{r_c} \right)^2 \right)^{-1/2} \right)^2$$

where $D(r)$ is the star surface density a projected distance r from the centre of the cluster.

k , r_c and r_t are constants, k being a scale factor and r_c and r_t the core and tidal radii respectively.

Moffat's formula gives the intensity $I(r)$ at a radial distance r from the centre of the star image as

$$I(r) = I_0 / \left(1 + \left(\frac{r}{R} \right)^2 \right)^{\beta}$$

where I_0 , R and β are all constants.

The total luminosity, L_t , of such a profile is

$$L_t = \frac{\pi R^2 I_0}{\beta - 1}$$

so

$$I(r) = \frac{L_t (\beta - 1)}{\pi R^2} \left(1 + \left(\frac{r}{R} \right)^2 \right)^{-\beta}$$

If the intensity threshold beyond which the profile is truncated is I_{th} , then the corresponding radius r_{th} is

$$r_{th} = \left(\frac{L_t (\beta - 1)}{I_{th} \pi R^2} \right)^{1/(\beta - 1)} R$$

from this, the fraction of the total light emitted beyond this boundary, f , may be calculated

$$f = \left(1 + \left(\frac{r_{th}}{R} \right)^2 \right)^{1 - \beta}$$

$$B = \frac{\pi \left(X - \left(\frac{IXEXT}{2} - 1 \right)^2 + \left(Y - \frac{IYEXT}{2} \right)^2 \right)^{1/2}}{A}$$

L^AT_EX OUTPUT

The optional globular cluster is generated using a King (1962) star density law

$$D(r) = k((1 + (r/r_c)^2)^{-1/2} - (1 + (r_t/r_c)^2)^{-1/2})^2 \quad (1)$$

where $D(r)$ is the star surface density a projected distance r from the centre of the cluster. k , r_c and r_t are constants, k being a scale factor and r_c and r_t the core and tidal radii respectively.

Moffat's formula gives the intensity $I(r)$ at a radial distance r from the centre of the star image as

$$I(r) = I_0 / (1 + (\frac{r}{R})^2)^\beta \quad (2)$$

where I_0 , R and β are all constants. The total luminosity, L_t , of such a profile is

$$L_t = \frac{\pi R^2 I_0}{\beta - 1} \quad (3)$$

so

$$I(r) = \frac{L_t(\beta - 1)}{\pi^2 R^2} / (1 + (\frac{r}{R})^2)^\beta \quad (4)$$

If the intensity threshold beyond which the profile is truncated is I_{th} , then the corresponding radius r_{th} is

$$r_{th} = ((\frac{L_t(\beta - 1)}{I_{th}\pi R^2})^{1/\beta} - 1)^{1/2} R \quad (5)$$

from this, the fraction of the total light emitted beyond this boundary, f , may be calculated

$$f = (1 + (\frac{r_{th}}{R})^2)^{1-\beta} \quad (6)$$

$$B = \frac{\pi((X - (\frac{IXEXT}{2} - 1))^2 + (Y - \frac{IYEXT}{2})^2)^{\frac{1}{2}}}{A}$$

An AR model is of the form

$$X_i = \sum_{j=1}^M A_j X_{i-j} + E_i$$

for equally spaced observations X_i and for a set of constants A_j . E_i is the error in using this model.

The method involves choosing the A_j to minimize the E_i .

The Q, U and E frames can now be calculated as follows:

$$\begin{aligned} Q_{ij} &= \frac{A_{ij} - B_{ij}}{A_{ij} + B_{ij}} \\ U_{ij} &= \frac{C_{ij} - D_{ij}}{C_{ij} + D_{ij}} \\ E_{ij} &= \frac{2}{A_{ij} + B_{ij} + C_{ij} + D_{ij}} \end{aligned}$$

The total polarization frame, P, and polarization angle frame, T, are generated from Q, U and (if required) E as follows:

$$\begin{aligned} P_{ij} &= \sqrt{Q_{ij}^2 + U_{ij}^2} - E_{ij} \\ T_{ij} &= 0.5 \arctan \frac{U_{ij}}{Q_{ij}} \end{aligned}$$

The values of T_{ij} are restricted to the range 0 to $+\pi$ radians.

Every pixel (X,Y) in the image frame is multiplied by $\text{SIN}(B)/B$ where

$$B = \frac{\pi}{2} \left(X - \frac{IXEXT}{2} - 1 \right)^2 + \left(Y - \frac{IYEXT}{2} \right)^2 \frac{1}{A}$$

L^AT_EX OUTPUT

An AR model is of the form

$$X_i = \sum_{j=1}^M A_j X_{i-j} + E_i \quad (7)$$

for equally spaced observations X_i and for a set of constants A_j . E_i is the error in using this model. The method involves choosing the A_j to minimize the E_i .

The Q, U and E frames can now be calculated as follows:

$$Q_{ij} = \frac{A_{ij} - B_{ij}}{A_{ij} + B_{ij}}$$

$$U_{ij} = \frac{C_{ij} - D_{ij}}{C_{ij} + D_{ij}}$$

$$E_{ij} = \frac{2}{A_{ij} + B_{ij} + C_{ij} + D_{ij}}$$

The total polarization frame, P, and polarization angle frame, T, are generated from Q, U and (if required) E as follows:

$$P_{ij} = \sqrt{Q_{ij}^2 + U_{ij}^2} - E_{ij}$$

$$T_{ij} = 0.5 \arctan \frac{U_{ij}}{Q_{ij}}$$

The values of T_{ij} are restricted to the range 0 to $+\pi$ radians.

Every pixel (X,Y) in the image frame is multiplied by $\text{SIN}(B)/B$ where

$$B = \frac{\pi((X - (\frac{IXEXT}{2} - 1))^2 + (Y - \frac{IYEXT}{2})^2)^{\frac{1}{2}}}{A}$$

8 Tabbing

```

\begin{quote}
  \begin{tabbing}
    ROUTINExxx\=ERRxFMTBADxx\==x8xxxx\=\kill
    \textbf{ROUTINE}\>\textbf{SYMBOL}\>\>\textbf{MEANING}\>\>\>
    \\
    ADDSCR:\>ERR\_FRMNUL\>= 1\>Frame null.\>
    \>ERR\_FRMNAC\>= 3\>Frame could not be accessed.\>
    \>ERR\_PARINV\>= 4\>Parameter name invalid.\>
    \\
    CNPAR:\>ERR\_PARANC\>= 2\>Parameter association not cancelled.\>
    \>ERR\_PARINV\>= 4\>Parameter name invalid.\>
    \\
    CTOI:\>ERR\_INPINV\>= 5\>Input invalid.\>
    \\
    CTROR:\>ERR\_INPINV\>= 5\>Input invalid.\>
  \end{tabbing}
\end{quote}

*****

\begin{tabbing}
  namexx\=positionxx\=maxdimsxx\=dimensxx\=pointerxx\=pointerxxx\=\kill
  \emph{name}\>\emph{default}\>\emph{maxels}\>\emph{value}\>\emph{actels}
  \>\>\textbf{RDKEYx}\>\>\>
  \emph{name}\>\>\>\emph{value}\>\emph{nels}\>\>\textbf{WRKEYx}\>\>\>
  \\
  \emph{name}\>\emph{dtype}\>\emph{ftype}\>\emph{size}\>\emph{pointer}
  \>\>\textbf{RDDATA, WRDATA}\>\>\>
  \emph{name}\>\emph{dtype}\>\emph{size}\>\emph{pointer}\>\>\textbf{GETDYN}\>\>\>
  \\
  \emph{name}\>\emph{dtype}\>\emph{maxdims}\>\emph{dimens}\>\emph{actdims}
  \>\emph{pointer}\>\textbf{RDIMAG}\>\>\>
  \emph{name}\>\emph{dtype}\>\emph{dimens}\>\emph{ndims}\>\emph{pointer}
  \>\textbf{WRIMAG}\>\>\>
\end{tabbing}

```

L^AT_EX OUTPUT

ROUTINE	SYMBOL		MEANING
ADDSCR:	ERR_FRMNUL	= 1	Frame null.
	ERR_FRMNAC	= 3	Frame could not be accessed.
	ERR_PARINV	= 4	Parameter name invalid.
CNPAR:	ERR_PARANC	= 2	Parameter association not cancelled.
	ERR_PARINV	= 4	Parameter name invalid.
CTOI:	ERR_INPINV	= 5	Input invalid.
CTOR:	ERR_INPINV	= 5	Input invalid.

<i>name</i>	<i>default</i>	<i>maxels</i>	<i>value</i>	<i>actels</i>		RDKEYx
<i>name</i>			<i>value</i>	<i>nels</i>		WRKEYx
<i>name</i>	<i>dtype</i>	<i>ftype</i>	<i>size</i>	<i>pointer</i>		RDDATA, WRDATA
<i>name</i>	<i>dtype</i>		<i>size</i>	<i>pointer</i>		GETDYN
<i>name</i>	<i>dtype</i>	<i>maxdims</i>	<i>dimens</i>	<i>actdims</i>	<i>pointer</i>	RDIMAG
<i>name</i>	<i>dtype</i>		<i>dimens</i>	<i>ndims</i>	<i>pointer</i>	WRIMAG

The following qualifiers are recognized:

```
\begin{list}{}{\settowidth{\labelwidth}{\texttt{-f}\emph{filename}}
  \setlength{\leftmargin}{\labelwidth}
  \addtolength{\labelwidth}{\labelsep}}
  \item[\texttt{-b}] Process pages in reverse order; this can be useful on the
  A2 model printers which stack their pages face up and therefore in the
  reverse of the order in which they were printed.
  \item[\texttt{-c\#}] Print \texttt{\#} copies of each page; a photocopier is
  cheaper so this qualifier shouldn't really be needed.
  \item[\texttt{-x\#}\textit{unit}] Set the left margin to \texttt{\#} (which
  can be both a real number and negative); \textit{unit} is one of:
```

```
\begin{tabular}{ll}
  bp & \big point (1in = 72bp)\
  cc & \cicero (1cc = 12dd)\
  cm & \centimetre (1in = 2.54cm)\
  dd & \didot point (1157dd = 1238pt)\
  in & \inch\
  mm & \millimetre\
  pc & \pica (1pc = 12pt)\
  pt & \point (72.27pt = 1in)\
  sp & \scaled point (65536sp = 1pt)
\end{tabular}
```

The default margin is 1in.

```
\item[\texttt{-y\#}\textit{unit}] Set top margin. The default is 1in.
\end{list}
```

```
\newlength{\numlen}
\settoheight{\numlen}{xxxx000--000--0000}
\settowidth{\labelsep}{000}
```

```
\begin{list}{}{\setlength{\labelwidth}{\numlen}\setlength{\leftmargin}{\numlen}
  \addtolength{\leftmargin}{\labelsep}}
  \item[0385--41191] (RDC) V21, (use 8-bit no-parity), connected to
  Departmental Gandalf PACX.
  PACX service is \texttt{STARN}.
  More details if you specify \texttt{HELP} instead of \texttt{STARN} after
  the Gandalf prompt.
  \item[061--273--5730] (RDC) V21/V23 (autobaud), seven bits, even parity,
  connected to VAX--11/750.
  \item[0477--71324] (RDC) V21/V23/V22/V22bis (autobaud), connected to a DECserver
  200.
  \item[0235--831--593] (RDC) VAX 11/780, V22.
  \item[0235--44--6951] PAD line V21/V23.
  \item[0235--44--6952] PAD line V22/V22bis.
\end{list}
```

L^AT_EX OUTPUT

The following qualifiers are recognized:

- b Process pages in reverse order; this can be useful on the A2 model printers which stack their pages face up and therefore in the reverse of the order in which they were printed.
- c# Print # copies of each page; a photocopier is cheaper so this qualifier shouldn't really be needed.
- x#*unit* Set the left margin to # (which can be both a real number and negative); *unit* is one of:
 - bp big point (1in = 72bp)
 - cc cicero (1cc = 12dd)
 - cm centimetre (1in = 2.54cm)
 - dd didot point (1157dd = 1238pt)
 - in inch
 - mm millimetre
 - pc pica (1pc = 12pt)
 - pt point (72.27pt = 1in)
 - sp scaled point (65536sp = 1pt)

The default margin is 1in.

- y#*unit* Set top margin. The default is 1in.

- 0385-41191 (RDC) V21, (use 8-bit no-parity), connected to Departmental Gandalf PACX. PACX service is STARN. More details if you specify HELP instead of STARN after the Gandalf prompt.
- 061-273-5730 (RDC) V21/V23 (autobaud), seven bits, even parity, connected to VAX-11/750.
- 0477-71324 (RDC) V21/V23/V22/V22bis (autobaud), connected to a DECserver 200.
- 0235-831-593 (RDC) VAX 11/780, V22.
- 0235-44-6951 PAD line V21/V23.
- 0235-44-6952 PAD line V22/V22bis.

9 Tables

```

\begin{table}
  \begin{center}
    \begin{tabular}{|c|c|c|} \hline
      \emph{ACCESS MODE} & \multicolumn{2}{c|}{\emph{MEDIUM}} \\ \cline{2-3}
      & \emph{Disk} & \emph{Tape} \\ \hline
      \emph{Sequential} & -- & BLOCKSIZE \\ \hline
      & FILENUMBER \\ \hline
      \emph{Direct} & NRECORDS & -- \\ \hline
      & KEYFIELD & \\ \hline
    \end{tabular}
    \caption{Parameters required for access mode and medium}
  \end{center}
\end{table}

```

```

\begin{table}
  \begin{center}
    \begin{tabular}{|l|l|l|} \hline
      Primitive data type & VAX FORTRAN type & HDS type \\ \hline
      Integer & & \texttt{ INTEGER} & \texttt{ '\_INTEGER'} \\ \hline
      Single floating point & & \texttt{ REAL} & \texttt{ '\_REAL'} \\ \hline
      Double floating point & & \texttt{ DOUBLE PRECISION} & \texttt{ '\_DOUBLE'} \\ \hline
      Logical & & \texttt{ LOGICAL} & \texttt{ '\_LOGICAL'} \\ \hline
      Character & & \texttt{ CHARACTER[*n]} & \texttt{ '\_CHAR[*n]'} \\ \hline
    \end{tabular}
    \caption{Standard Primitive Data Types}
  \end{center}
\end{table}

```

L^AT_EX OUTPUT

<i>ACCESS MODE</i>	<i>MEDIUM</i>	
	<i>Disk</i>	<i>Tape</i>
<i>Sequential</i>	–	BLOCKSIZE FILENUMBER
<i>Direct</i>	NRECORDS KEYFIELD	–

Table 1: Parameters required for access mode and medium

Primitive data type	VAX FORTRAN type	HDS type
Integer	INTEGER	'_INTEGER'
Single floating point	REAL	'_REAL'
Double floating point	DOUBLE PRECISION	'_DOUBLE'
Logical	LOGICAL	'_LOGICAL'
Character	CHARACTER[*n]	'_CHAR[*n]'

Table 2: Standard Primitive Data Types

```

\begin{table}
\begin{center}
\begin{tabular}{|l|l|l|} \hline
\multicolumn{2}{|c|}{\textbf{R.A.}} & \multicolumn{2}{|c|}{\textbf{DEC.}} \\ \hline
Accuracy used & Window size & Accuracy used & Window size \\ \hline
Hours only & \pm$30 mins & Degrees Only & \pm$4 Degr \\ \hline
Hours & \& minutes & \pm$10 mins & Degrees & \& minutes & \pm$25 mins \\ \hline
Hours, mins & \& secs & \pm$30 Secs & Degrees, mins & \& secs & \pm$1 min \\ \hline
\end{tabular}
\end{center}
\end{table}

```

```

\begin{center}
\begin{tabular}{c|p{33em}}
\textbf{<$fac>} & \textbf{Facility provides \ldots } \\ \hline
\\
VAL & Arithmetic, mathematical functions and type conversion on single
(scalar) \emph{values}.
Handling of numerical errors and \emph{bad value} propagation are
incorporated. \\
\\
VEC & Arithmetic, mathematical functions and type conversion on \emph{vectorised arrays},
allowing more efficient processing of large numbers of
data.
Handling of numerical errors and \emph{bad value} propagation are
incorporated. \\
\\
\end{tabular}
\end{center}

```

L^AT_EX OUTPUT

R.A.		DEC.	
Accuracy used	Window size	Accuracy used	Window size
Hours only	±30 mins	Degrees Only	±4 Degrs
Hours & minutes	±10 mins	Degrees & minutes	±25 mins
Hours, mins & secs	±30 Secs	Degrees, mins & secs	±1 min

<fac>	Facility provides...
VAL	Arithmetic, mathematical functions and type conversion on single (scalar) <i>values</i> . Handling of numerical errors and <i>bad value</i> propagation are incorporated.
VEC	Arithmetic, mathematical functions and type conversion on <i>vectorised arrays</i> , allowing more efficient processing of large numbers of data. Handling of numerical errors and <i>bad value</i> propagation are incorporated.

10 Figures

```

\begin{figure}
  \begin{center}
    \begin{picture}(142,80)
      \thicklines
      \put (0,72){Parameter}
      \put (20,72){Value: \textbf{RDKEYx},\textbf{WRKEYx}}
      \put (2,69){access}
      \put (20,64){Frame:}
      \put (39,64){Basic}
      \put (55,64){Data: \textbf{RDDATA, WRDATA}}
      \put (37,61){routines}
      \put (55,58){Descriptor}
      \put (76,58){complete: \textbf{CYDSCR}}
      \put (76,53){items}
      \put (91,53){values: \textbf{RDDSCR, WRDSCR}}
      \put (103,50){\textbf{ADDSCR, DLDSR}}
      \put (91,45){names: \textbf{RDDSCN}}
      \put (37,40){\emph{IMAGE} type: \textbf{RDIMAG, WRIMAG}}
      \put (20,32){Error: \textbf{WRERR}}
      \put (0,25){Parameter: \textbf{CNPAR}}
      \put (2,22){control}
      \put (0,15){Utilities}
      \put (20,15){data conversion: \textbf{CTOx, xTOC}}
      \put (20,10){mapping control: \textbf{GETDYN, FRDATA}}
      \put (20,5){direct terminal I/O: \textbf{RDUSER, WRUSER}}
      \put (20,0){error handler: \textbf{STLERR}}
      \put (16,73){\line(1,0){4}}
      \put (18,65){\line(1,0){2}}
      \put (31,65){\line(1,0){8}}
      \put (47,65){\line(1,0){8}}
      \put (51,59){\line(1,0){4}}
      \put (71,59){\line(1,0){5}}
      \put (73.5,54){\line(1,0){2.5}}
      \put (84,54){\line(1,0){7}}
      \put (87.5,46){\line(1,0){3.5}}
      \put (35,41){\line(1,0){2}}
      \put (18,33){\line(1,0){2}}
      \put (12.5,16){\line(1,0){7.5}}
      \put (16,11){\line(1,0){4}}
      \put (16,6){\line(1,0){4}}
      \put (16,1){\line(1,0){4}}
      \put (16,16){\line(0,-1){15}}
      \put (18,73){\line(0,-1){40}}
      \put (35,65){\line(0,-1){24}}
      \put (51,65){\line(0,-1){6}}
      \put (73.5,59){\line(0,-1){5}}
      \put (87.5,54){\line(0,-1){8}}
    \end{picture}
    \caption{Functional analysis of INTERIM routines}
    \label{functional_analysis_of_interim_routine}
  \end{center}
\end{figure}

```



```
\end{center}  
\end{figure}
```

L^AT_EX OUTPUT

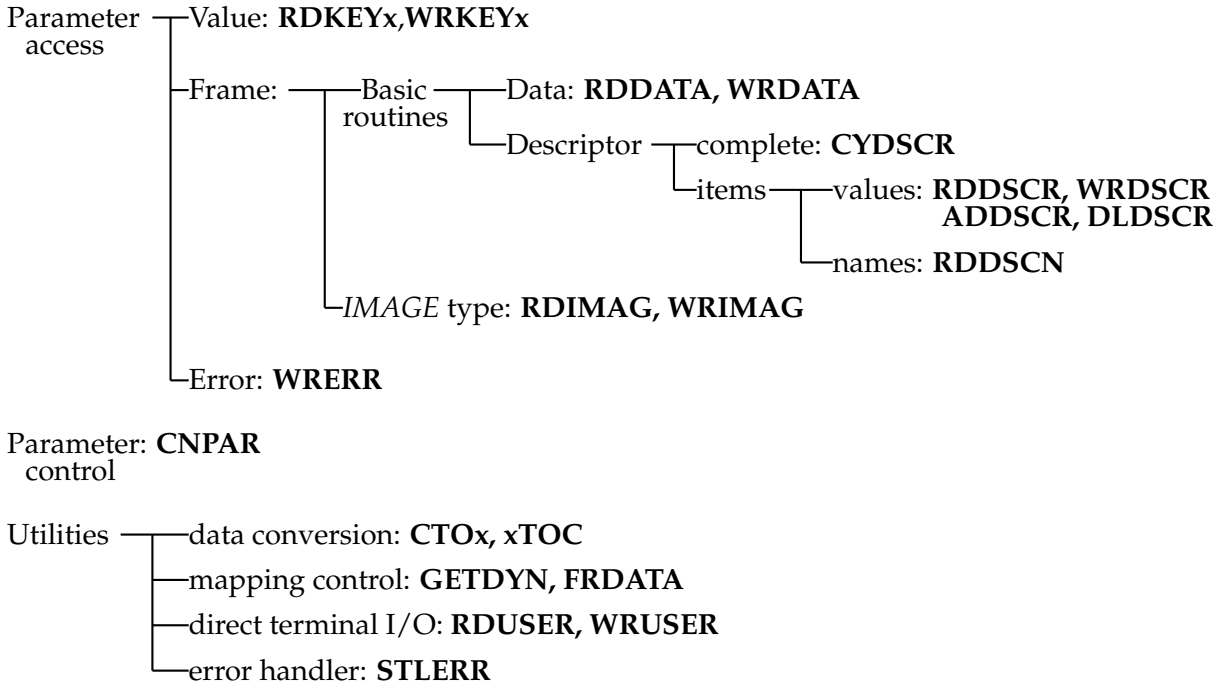

Figure 1: Functional analysis of INTERIM routines

```

\begin{figure}
  \begin{center}
    \begin{picture}(70,50)
      \thicklines
      \put (0,0){\framebox(30,5){Help Libraries}}
      \put (40,0){\framebox(30,5){Human Help}}
      \put (0,20){\framebox(30,5){Help}}
      \put (0,40){\framebox(30,5){CAR}}
      \put (15,20){\vector(0,-1){15}}
      \put (15,40){\vector(0,-1){15}}
      \put (55,12.5){\vector(0,-1){7.5}}
      \put (55,32.5){\vector(0,-1){7.5}}
      \put (15,12.5){\line(1,0){40}}
      \put (15,32.5){\line(1,0){45}}
      \put (63,32.5){\ldots}
      \put (53,22.5){\ldots}
    \end{picture}
    \caption{SCAR Help system}
    \label{scar_help_system}
  \end{center}
\end{figure}

```

```

\begin{figure}
  \begin{center}
    \begin{picture}(135,46)
      \thicklines
      \put (30,17){\line (1,0){20}}
      \put (50,17){\line (0,1){11}}
      \put (30,17){\line (0,1){3}}
      \put (30,20){\line (5,1){10}}
      \put (40,22){\line (1,6){1}}
      \put (41,28){\line (1,0){9}}
      \put (70,0){\framebox(20,5){MEMORY}}
      \put (70,20){\framebox(20,5){MAIN}}
      \put (70,40){\framebox(20,5){INPUT}}
      \put (110,20){\framebox(20,5){OUTPUT}}
      \put (50,22.5){\vector (1,0){20}}
      \put (90,22.5){\vector (1,0){20}}
      \put (80,40){\vector (0,-1){15}}
      \put (79,20){\vector (0,-1){15}}
      \put (81,5){\vector (0,1){15}}
      \put (41,19){VDU}
      \put (57.5,23.5){I,R}
      \put (98,23.5){w}
      \put (76,12.5){+}
      \put (82,12.5){--}
      \put (81,32.5){P,S}
      \put (0,40){\textbf{EDIT} mode:}
    \end{picture}
    \caption{Data flow in the editing process}
    \label{data_flow_in_the_editing_process}
  \end{center}
\end{figure}

```

TEX OUTPUT

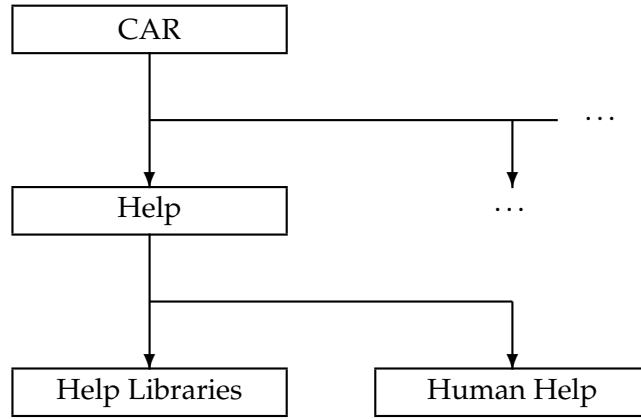

Figure 2: SCAR Help system

EDIT mode:

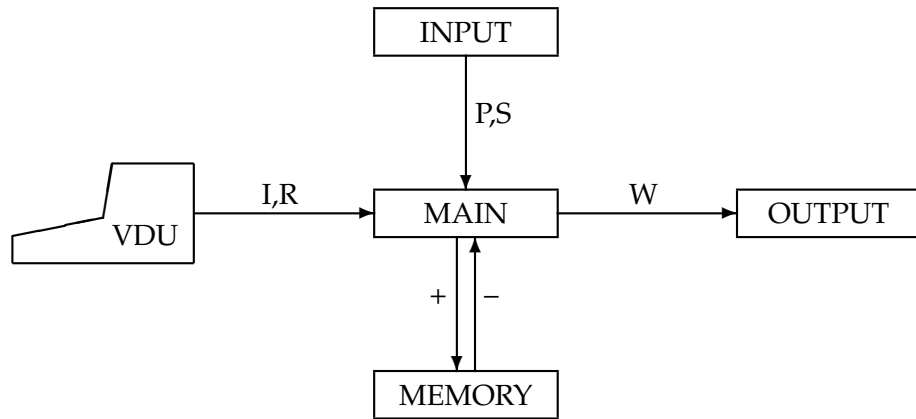

Figure 3: Data flow in the editing process

```

\begin{figure}
  \begin{center}
    \begin{picture}(150,90)
      \thicklines
      \put (20,70){\framebox(30,5){SYSTEM}}
      \put (0,55){\framebox(30,5){ACCOUNT}}
      \put (40,55){\framebox(30,5){ACCOUNT}}
      \put (40,45){\framebox(30,5){Directory}}
      \put (20,30){\framebox(30,5){File}}
      \put (60,30){\framebox(30,5){File}}
      \put (100,30){\framebox(30,5){Container File}}
      \put (100,20){\framebox(30,5){Object}}
      \put (80,5){\framebox(30,5){Object}}
      \put (120,5){\framebox(30,5){Object}}
      \put (15,65){\vector(0,-1){5}}
      \put (55,65){\vector(0,-1){5}}
      \put (55,55){\vector(0,-1){5}}
      \put (35,40){\vector(0,-1){5}}
      \put (75,40){\vector(0,-1){5}}
      \put (115,30){\vector(0,-1){5}}
      \put (95,15){\vector(0,-1){5}}
      \put (135,15){\vector(0,-1){5}}
      \put (90,32.5){\vector(1,0){10}}
      \put (100,32.5){\vector(-1,0){10}}
      \put (35,70){\line(0,-1){5}}
      \put (55,45){\line(0,-1){5}}
      \put (115,20){\line(0,-1){5}}
      \put (15,65){\line(1,0){40}}
      \put (35,40){\line(1,0){40}}
      \put (95,15){\line(1,0){40}}
      \put (15,55){\line(0,-1){1}}
      \put (15,53){\line(0,-1){1}}
      \put (15,51){\line(0,-1){1}}
      \put (20,80){\textbf{VMS File System}}
      \put (110,80){\textbf{HDS}}
    \end{picture}
    \caption{The relationship between VMS and HDS}
    \label{the_relationship_between_VMS_and_HDS}
  \end{center}
\end{figure}

```

LaTeX OUTPUT

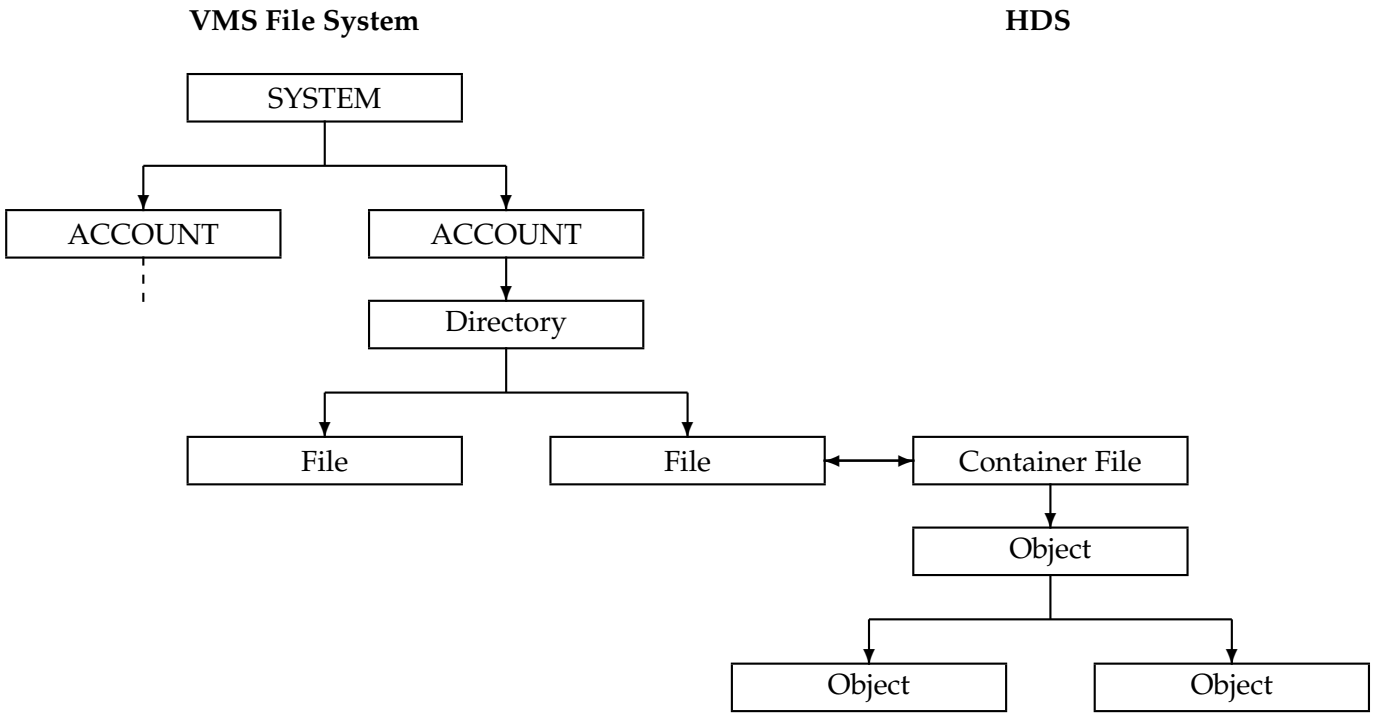

Figure 4: The relationship between VMS and HDS

```

\begin{figure}
  \begin{center}
    \begin{picture}(130,43)
      \thicklines
      \put (7,40){P(n)}
      \put (67,40){S(n)}
      \put (67,30){P(n)}
      \put (82,30){P(n)}
      \put (97,30){P(n)}
      \put (7,30){S(n)}
      \put (7,20){P(n)}
      \put (22,20){S(n)}
      \put (37,20){P(n,n,n)}
      \put (22,10){P(n)}
      \put (37,10){P(n)}
      \put (52,10){S(n,n)}
      \put (52,0){P(n)}
      \put (67,0){P(n,n,n,n)}
      \put (70,38){\line(0,-1){4}}
      \put (70,36){\line(1,0){30}}
      \put (85,36){\line(0,-1){2}}
      \put (100,36){\line(0,-1){2}}
      \put (10,28){\line(0,-1){4}}
      \put (10,26){\line(1,0){30}}
      \put (25,26){\line(0,-1){2}}
      \put (40,26){\line(0,-1){2}}
      \put (25,18){\line(0,-1){4}}
      \put (25,16){\line(1,0){30}}
      \put (40,16){\line(0,-1){2}}
      \put (55,16){\line(0,-1){2}}
      \put (55,8){\line(0,-1){4}}
      \put (55,6){\line(1,0){15}}
      \put (70,6){\line(0,-1){2}}
      \put (100,15){\textbf{KEY}}
      \put (90,10){S(n) --- Structure object}
      \put (90,5){P(n) --- Primitive object}
    \end{picture}
    \caption{Diagrams of Structure Objects}
    \label{diagrams_of_structure_objects}
  \end{center}
\end{figure}

```

L^AT_EX OUTPUT

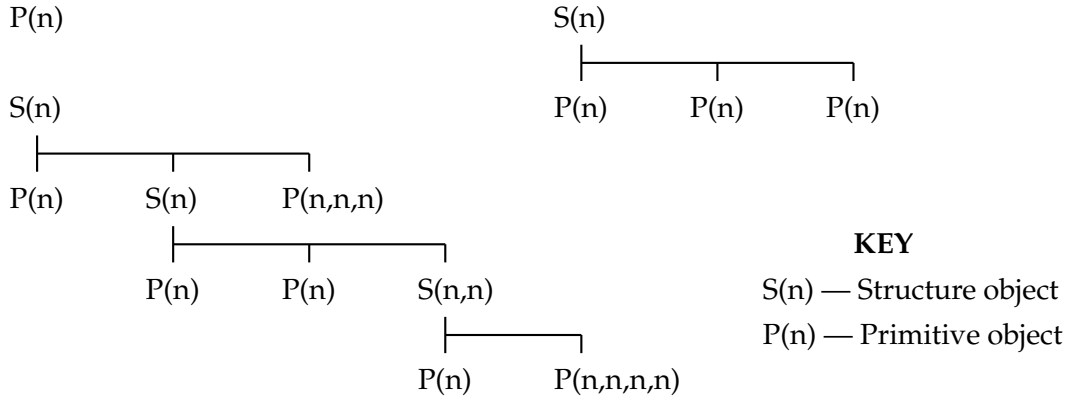

Figure 5: Diagrams of Structure Objects

```

\begin{figure}
  \begin{center}
    \begin{picture}(110,35)
      \thicklines
      \put (40,30){\framebox(30,5){SKY\_POSITION}}
      \put (40,25){\framebox(30,5){[equatorial]}}
      \put (0,10){\framebox(30,5){RA}}
      \put (0,5){\framebox(30,5){[\_char*12]}}
      \put (0,0){\framebox(30,5){'10:59:17.20'}}
      \put (40,10){\framebox(30,5){DEC}}
      \put (40,5){\framebox(30,5){[\_char*12]}}
      \put (40,0){\framebox(30,5){'47:23:15.00'}}
      \put (80,10){\framebox(30,5){EQUINOX}}
      \put (80,5){\framebox(30,5){[\_char*7]}}
      \put (80,0){\framebox(30,5){'B1950.0'}}
      \put (15,20){\line(1,0){80}}
      \put (15,20){\vector(0,-1){5}}
      \put (55,25){\vector(0,-1){10}}
      \put (95,20){\vector(0,-1){5}}
    \end{picture}
    \caption{An Alternative Representation for SKY\_POSITION}
    \label{an_alternative_representation_for_sky_position}
  \end{center}
\end{figure}

```

```

\begin{figure}
  \begin{center}
    \begin{picture}(40,25)
      \thicklines
      \put (0,20){\framebox(40,5){parent RID}}
      \put (0,15){\framebox(25,5){reserve}}
      \put (25,15){\framebox(5,5){M}}
      \put (30,15){\framebox(5,5){Z}}
      \put (35,15){\framebox(5,5){A}}
      \put (0,10){\framebox(5,5){C}}
      \put (5,10){\framebox(15,5){class}}
      \put (20,10){\framebox(20,5){size}}
      \put (0,5){\framebox(40,5){domain (S) length}}
      \put (0,0){\framebox(40,5){domain (D) length}}
      \put (42,22){(24 bits)}
      \put (42,17){($5+1+1+1$ bits)}
      \put (42,12){($1+3+4$ bits)}
      \put (42,7){(8 bits)}
      \put (42,2){(32 bits)}
    \end{picture}
    \caption{Structure of a Record Control Label}
    \label{structure_of_a_record_control_label}
  \end{center}
\end{figure}

```

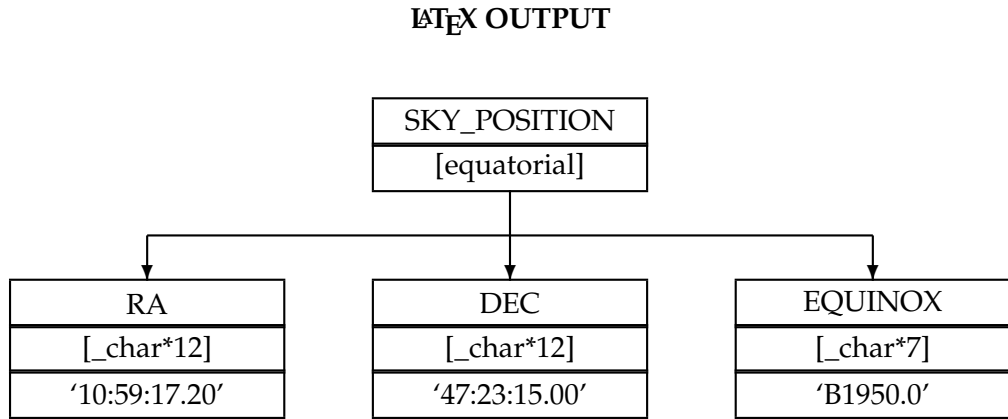

Figure 6: An Alternative Representation for SKY_POSITION

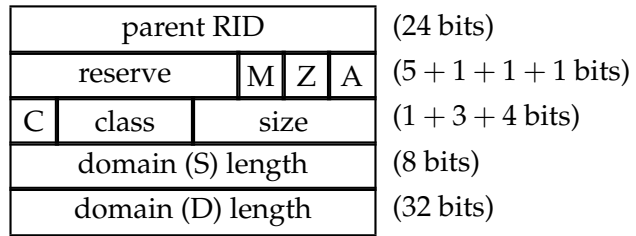

Figure 7: Structure of a Record Control Label

Put this before the ‘begin{document}’ command:

```
\providecommand {\radec}  {\alpha,\delta\,}
\providecommand {\mhadec} {\[-h,\delta\,}
\providecommand {\azel}   {[A,E\,]}
```

Put this in the main body of your text:

```
\begin{figure}
\begin{small}
\begin{center}
\begin{tabular}{|cccc|} \hline
& & & & & & & & & \\
& & \rightarrow & & MEAN \radec & & \downarrow & & & \\
& & & & & & \downarrow & & & \\
& & & & J2000 FK5 MEAN \radec & & \downarrow & & & \\
& & & & & & \downarrow & & & \\
& & & & annual aberration & & \downarrow & & & \\
& & & & light deflection & & \downarrow & & & \\
& & & & precession/nutation & & \downarrow & & & \\
& & & & & & \downarrow & & & \\
& & \rightarrow & & APPARENT \radec & & \downarrow & & & \\
& & & & & & \downarrow & & & \\
& & & & Earth rotation & & \downarrow & & & \\
& & & & & & \downarrow & & & \\
& & & & APPARENT \mhadec & & \downarrow & & & \\
& & & & & & \downarrow & & & \\
& & & & diurnal aberration & & \downarrow & & & \\
& & & & & & \downarrow & & & \\
& & & & TOPOCENTRIC \mhadec & & \downarrow & & & \\
& & & & & & 20~Hz & & & \\
& & & & \mhadec\ to \azel & & \downarrow & & & \\
& & & & & & \downarrow & & & \\
& & \rightarrow & & TOPOCENTRIC \azel & & \downarrow & & & \\
& & & & & & \downarrow & & & \\
& & & & refraction & & \downarrow & & & \\
& & & & & & \downarrow & & & \\
& & & & OBSERVED \azel & & \downarrow & & & \\
& & & & & & \downarrow & & & \\
& & & & azimuth axis tilt & & \downarrow & & & \\
& & & & & & \downarrow & & & \\
& & & & tube flexure & & \downarrow & & & \\
& & & & Az/El nonperpendicularity & & \downarrow & & & \\
& & & & position of instrument rotator & & \downarrow & & & \\
& & & & pointing axis & & \downarrow & & & \\
& & & & & & \downarrow & & & \\
& & \rightarrow & & MOUNT \azel & & \downarrow & & & \\
& & & & & & \downarrow & & & \\
& & & & \fbox{SERVO} & & & & & \\
& & & & & & \uparrow & & & \\
& & & & CORRECTED ENCODER \azel & & \uparrow & & & \\
& & & & & & \uparrow & & & \\
& & & & gear & & & & & \\
& & & & encoder indexing errors & & \uparrow & & & \\
& & & & encoder errors & & \uparrow & & & \\
& & & & & & \uparrow & & & \\
& & & & & & \uparrow & & & \end{tabular}
\end{center}
\end{small}
\end{figure}
```

```

      &                &      RAW ENCODER \azel      &      $\uparrow$      & \\
      &                &                &                &                & \\
      &                &                &                &                & \\
                                           \hline
  \end{tabular}
  \end{center}
\end{small}
\caption{The pointing flow}
The set of transformations shown describes the relationship between the target
position (one of those marked $\rightarrow$) and the required telescope encoder
readings.  There are two major transformations: \radec\ to \mhadec, and \mhadec\
to azimuth and elevation \azel.  The others are all minor.
\end{figure}
```

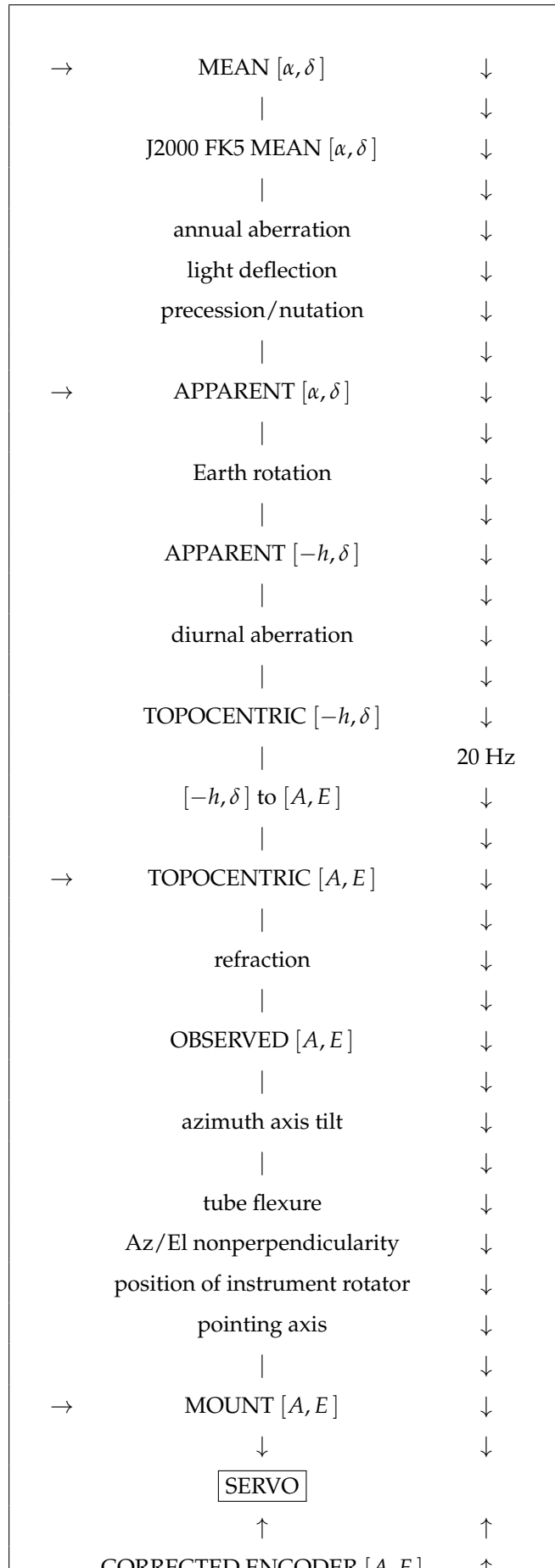

```

\begin{figure}
  \begin{small}
    \begin{center}
      \begin{tabular}{|cccccc|} \hline
        & & & & & \\\
        \hspace{6em} & \hspace{6em} & \hspace{6em} & & & \\
        \hspace{6em} & \hspace{6em} & \hspace{6em} & \hspace{6em} & \hspace{6em} & \\
        \multicolumn{2}{|c|}{\hspace{1em}\fbox{FK4, any eqnx}\$\Leftarrow\$} & & & & \\
        \multicolumn{2}{|c|}{\hspace{1em}\fbox{FK4, no $\mu$, any eqnx}\$\Leftarrow\$} & & & & \\
        \multicolumn{2}{|c|}{\hspace{1em}\fbox{FK5, any eqnx}\$\Leftarrow\$} & & & & \\
        & \multicolumn{2}{|c|}{} & \multicolumn{2}{|c|}{} & & \\
        & \multicolumn{2}{|c|}{space motion} & \multicolumn{1}{|c|}{} & & & \\
        & \multicolumn{2}{|c|}{space motion} & & & & \\
        \multicolumn{2}{|c|}{-- E-terms} & & & & & \\
        & \multicolumn{2}{|c|}{-- E-terms} & \multicolumn{1}{|c|}{} & & & \\
        \multicolumn{2}{|c|}{prec to B1950} & \multicolumn{2}{|c|}{prec to B1950} & & & \\
        & \multicolumn{2}{|c|}{prec to J2000} & & & & \\
        \multicolumn{2}{|c|}{+ E-terms} & & & & & \\
        & \multicolumn{2}{|c|}{+ E-terms} & \multicolumn{1}{|c|}{} & & & \\
        \multicolumn{2}{|c|}{to J2000, no $\mu$} & \multicolumn{1}{|c|}{} & & & & \\
        & \multicolumn{2}{|c|}{} & & & & \\
        \multicolumn{2}{|c|}{parallax} & \multicolumn{1}{|c|}{} & & & & \\
        & \multicolumn{2}{|c|}{parallax} & & & & \\
        \multicolumn{2}{|c|}{to J2000} & \multicolumn{2}{|c|}{to J2000, no $\mu$} & & & \\
        & \multicolumn{1}{|c|}{} & & & & & \\
        & \multicolumn{2}{|c|}{} & \multicolumn{2}{|c|}{} & & \cline{2-5} \\
        \multicolumn{3}{|c|}{} & & & & \\
        & & \multicolumn{2}{|c|}{\fbox{FK5, J2000}} & & & \\
        \multicolumn{3}{|c|}{} & & & & \cline{3-4} \\
        & & \multicolumn{2}{|c|}{} & & & \\
        & \multicolumn{2}{|c|}{to B1950, no $\mu$} & \multicolumn{1}{|c|}{} & & & \\
        & \multicolumn{2}{|c|}{fictitious $\mu$} & \multicolumn{1}{|c|}{} & & & \\
        & \multicolumn{2}{|c|}{-- E-terms} & \multicolumn{1}{|c|}{} & & & \\
        & \multicolumn{2}{|c|}{prec to given eqnx} & & & & \\
        & \multicolumn{2}{|c|}{prec to given eqnx} & & & & \\
        & \multicolumn{2}{|c|}{+ E-terms} & \multicolumn{1}{|c|}{} & & & \\
        & & \multicolumn{2}{|c|}{} & & & \\
        & \multicolumn{2}{|c|}{} & & & & \\
        & \multicolumn{2}{|c|}{\hspace{1em}\fbox{FK4, given eqnx, curr ep}\$\leftarrow\$} & & & & \\
        & & \multicolumn{2}{|c|}{} & & & \\
        & \multicolumn{2}{|c|}{\hspace{1em}\fbox{FK5, given eqnx, curr ep}\$\leftarrow\$} & & & & \\
        & & \multicolumn{2}{|c|}{} & & & \\
        & \multicolumn{2}{|c|}{-- E-terms} & \multicolumn{1}{|c|}{} & & & \\
        & \multicolumn{2}{|c|}{prec to B1950} & & & & \\
        & \multicolumn{2}{|c|}{prec to J2000} & & & & \\
        & \multicolumn{2}{|c|}{+ E-terms} & \multicolumn{1}{|c|}{} & & & \\
        & \multicolumn{2}{|c|}{to J2000, no $\mu$} & \multicolumn{1}{|c|}{} & & & \\
        & & \multicolumn{2}{|c|}{} & & & \cline{3-4} \\
        \multicolumn{3}{|c|}{} & & & & \\
        & & \multicolumn{2}{|c|}{\fbox{FK5, J2000, curr ep}} & & & \\
        \multicolumn{3}{|c|}{} & & & & \\
        & & \multicolumn{2}{|c|}{light deflection} & & & \\
        & & \multicolumn{2}{|c|}{annual aberration} & & & \\
        & & \multicolumn{2}{|c|}{precession/nutation} & & & \\
      \end{tabular}
    \end{center}
  \end{small}
\end{figure}

```

```

\multicolumn{3}{|c|}{ } & & \\\
& & \multicolumn{2}{c}{\Rightarrow\fbbox{Apparent}\leftarrow} & & \\\
& & & & \\\
& & & & \\\ \hline
\end{tabular}
\end{center}
\end{small}
\caption{Transformations for mean \radec}
The forms marked  $\Rightarrow$  are those available for target data entry (target coordinates)
a choice of four; the forms marked  $\rightarrow$  are available for telescope control (tracking
coordinates). Pick one of each and follow the flow downwards. The sequences down to the chosen
tracking coordinates have only to be executed once per new target, but all the transformations
from that level down have to be performed at the full pointing rate.
\end{figure}

```

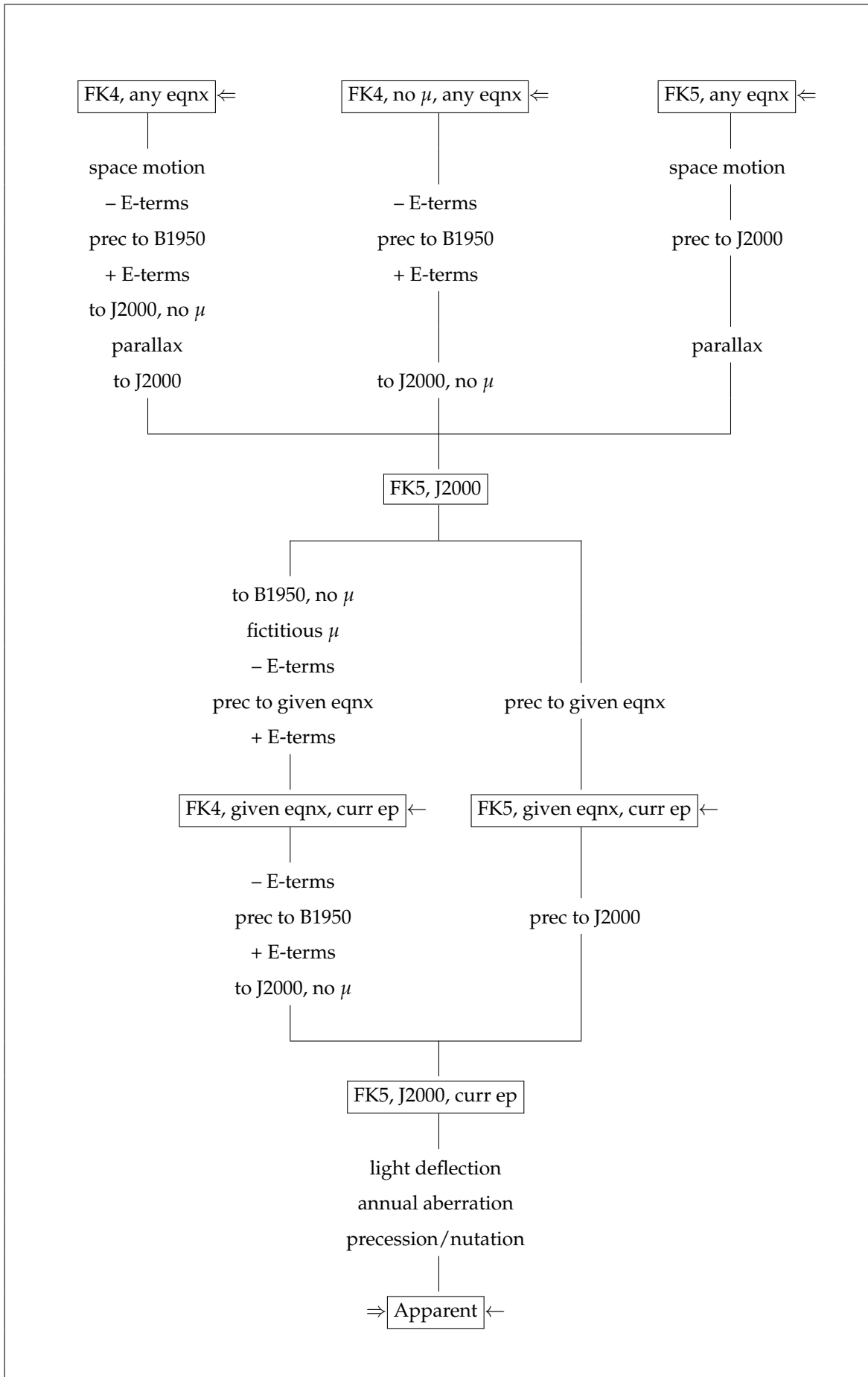

```

\begin{center}
\begin{picture}(120,100)
\put(60,50){\oval(100,80)}
\put(50,85){\makebox(20,5){Base}}
\put(20,40){\framebox(50,40)[t1]{Frame}}
\put(25,60){\framebox(40,15)[t1]{Data}}
\put(27,63){\circle*{1}}
\put(29,66){\circle*{1}}
\put(35,66){\circle*{1}}
\put(39,64){\circle*{1}}
\put(40,67){\circle*{1}}
\put(42,66){\circle*{1}}
\put(46,69){\circle*{1}}
\put(50,67){\circle*{1}}
\put(51,70){\circle*{1}}
\put(54,70){\circle*{1}}
\put(56,68){\circle*{1}}
\put(63,73){\circle*{1}}
\put(28,64){\line(5,1){34}}
\put(25,45){\framebox(25,10)[t1]{Data}}
\put(25,48){\line(1,0){2}}
\put(27,48){\line(0,-1){2}}
\put(27,46){\line(1,0){2}}
\put(29,46){\line(0,1){1}}
\put(29,47){\line(1,0){2}}
\put(31,47){\line(0,1){2}}
\put(31,49){\line(1,0){2}}
\put(33,49){\line(0,1){3}}
\put(33,52){\line(1,0){2}}
\put(35,52){\line(0,1){1}}
\put(35,53){\line(1,0){2}}
\put(37,53){\line(0,-1){3}}
\put(37,50){\line(1,0){2}}
\put(39,50){\line(0,1){1}}
\put(39,51){\line(1,0){2}}
\put(41,51){\line(0,-1){3}}
\put(41,48){\line(1,0){2}}
\put(43,48){\line(0,1){1}}
\put(43,49){\line(1,0){2}}
\put(45,49){\line(0,-1){2}}
\put(45,47){\line(1,0){2}}
\put(47,47){\line(0,1){3}}
\put(47,50){\line(1,0){2}}
\put(49,50){\line(0,-1){2}}
\put(49,48){\line(1,0){1}}
\put(40,40){\line(0,-1){20}}
\put(40,20){\line(1,0){50}}
\put(90,20){\line(0,1){50}}
\put(90,70){\line(-1,0){20}}
\put(70,40){\shortstack[l]{t discovery \\ ~all agreed \\ obel Prize. \\ ummed up \\ the moon".}}
\put(72,22){\framebox(16,16)[t1]{Data}}
\put(80,30){\circle{10}}
\put(80,30){\vector(-1,4){1}}

```

```
\put(80,30){\vector(-1,0){3}}
\put(80,30){\vector(-4,-1){7.5}}
\put(80,30){\vector(-1,-1){4.5}}
\put(80,30){\vector(-1,-3){1.2}}
\put(47,31){\shortstack[l]{Vector display \\ of the results. }}
\put(25,40){\line(0,-1){5}}
\put(25,35){\line(1,0){15}}
\put(70,72){\line(1,0){7}}
\put(77,72){\line(0,-1){2}}
\end{picture}
\end{center}
```

L^AT_EX OUTPUT

